

Melt Pressure Transducer Data Sheet

Industrial Pressure Transducer

Model: CMPT124G-111T

Introduction

◆ The model CMPT124G-111T comes with thermocouple, it can measure the pressure and temperature at one point.. This series can be used together with the N Series Intelligent Digital Pressure Instrument of Cheemi or other brand instrumentation. Zero & full span can be adjustable, with amplify signal can be connected with PLC. With the advantage of high precision and reliable pressure measuring and good quality, internal 80% calibration and etc.

Application

- ◆ Chemical fiber Equipment
- ◆ Plastic and Rubber manufacturing equipment
- ◆ Measure and Control all kinds of melt fluid

Features:

- ◆ High-standard quality
- ◆ Stainless steel Seal
- ◆ Simple Installation
- ◆ 80% inner calibration
- ◆ Excellent stability and repeatability



Dimensions(mm):

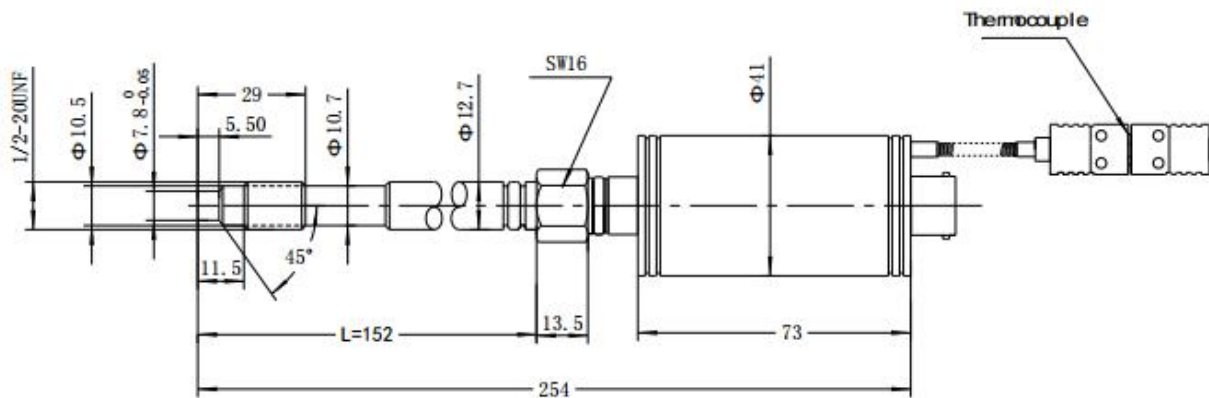

Remark: L=152, 228,305

Technical Characteristics

Model	CMPT124G-111T
Range	0... 3.5Mpa to 0... 150MPa

Melt Pressure Transducer Data Sheet

Output	2mV/V; 3.33mV/V
Accuracy	±1.0%FS
Input voltage	10VDC
Repeatability	±0.2%
Construction	Wheatstone bridge
Bridge resistance	350 ohms±10%
Overload pressure	1.5×FSO
Internal calibration	80%FSO±1%
Insulation Resistance	1000Megohms @50Vdc
Max. Diaphragm Temp	350°C
Electric connector	5PIN, 6PIN
Process connector	1/2"-20UNF, M14×1.5, M18×1.5 (Customer design)
Thermocouple type:	J,K,E,PT100 Optional

Mounting hole

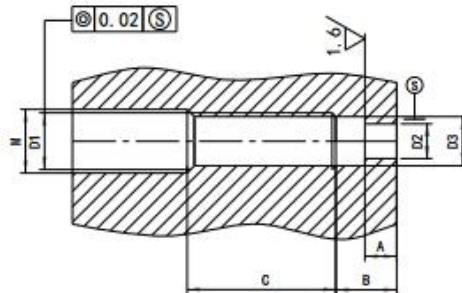
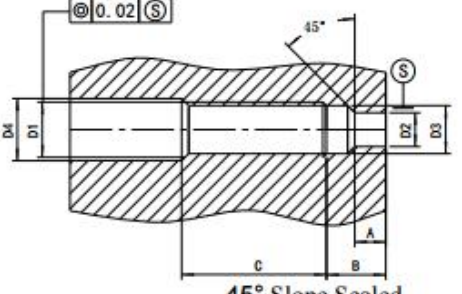
 <p style="text-align: center;">Planar Sealed</p>	D1	M22*1.5	M28*1.5	G3/4"	PT3/8"
	D2	Φ 16.1	Φ 18.3	Φ 18.3	Φ 10.3
	D3	Φ 20.1	Φ 26.1	Φ 24.2	Φ 14.9
	M	Φ 23	Φ 30	Φ 21	Φ 11
	A	11	12	12	14
	B	12	15	15	19
	C	40	35	35	40
 <p style="text-align: center;">45° Slope Sealed</p>	D1	M12*1.5	M14*1.5	1/2-20 UNF	M18*1.5
	D2	Φ 8	Φ 8	Φ 8	Φ 10.1
	D3	Φ 10.8	Φ 12.5	Φ 11.5	Φ 16.1
	D4	Φ 12.5	Φ 14.5	Φ 13.1	Φ 20
	A	6	6	6	6.5

Melt Pressure Transducer Data Sheet

	B	9	9.5	9.5	10
--	---	---	-----	-----	----

Attention for installation

◆ **Installation** Do not remove protective cap until ready to install. Prior to initial installation, verify correct machining of mounting hole. Install with aluminum gasket. The electronics housing should be secured, with the enclosed mounting bracket.

◆ **Remove** Make sure that there is no remained metal or plastic; remove all of the transducers from the equipment before you clean the extruder. You can remove the transducer only when the polymer is molten. And clean the diaphragm of the transducer with soft cloth as soon as you remove it. At the same time, you can use ZHYQ's cleaning tool kit to clean the remained material in the mounting hole in order to install easily next time.

◆ **Start-up** Bring system to operating temperature, and with no pressure, follow recommended procedures with instrumentation for zero and span adjustment. Make sure that there is sufficient "soak time" to assure that any material at the tip of the transducer is molten before process is started.

◆ **Electrical house** The tip of the transducer can endure high temperature, but the shell (electrical house) only endure temperature lower than 80°C, so it should place in the room temperature. It can benefit for the accuracy and natural life of the transducer if you keep the shell from the high temperature.

◆ **Overload effect** During the course of pressure measuring and controlling, it is better to make sure the transducer within the rated pressure, too long time overload the pressure will affect the accuracy and natural life of transducer, although the transducer own determinate overload ability.

◆ **Wiring** Use shielded cable, attach cable shield to ground at one end only. In order to prevent the jamming.

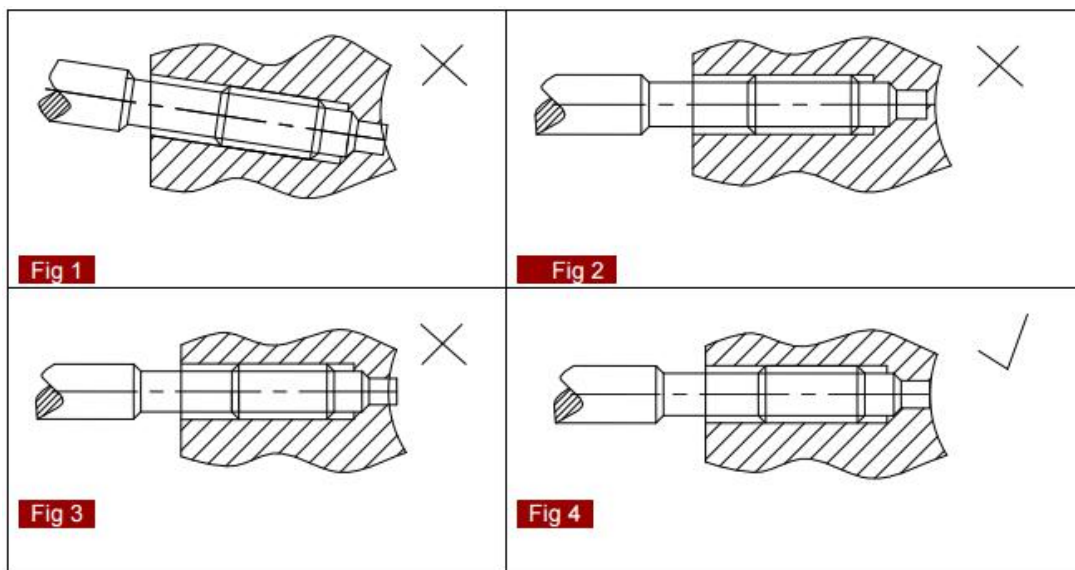

Melt Pressure Transducer Data Sheet

Wiring diagram

Output	Function	Color	5PIN
0/5V;1-5V; 0/10V 0/0.5V 2.0mV/V	Signal +	Blue	1
	Excitation +	Red	2
	Signal -	White	3
	Excitation -	Yellow	4
	Calibration	Black	5
Output	Function	Color	5PIN
4/20mA	Signal+	Blue	1
	Excitation+	Red	2
	Calibration	Yellow	4
	Calibration	Black	5

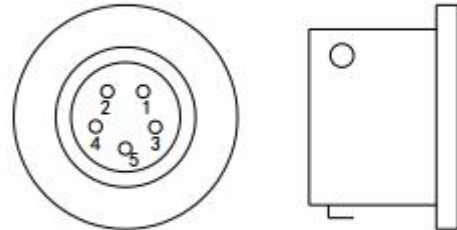

Output	Function	Color	6PIN
0-5V;1-5V; 0-10V; 0/0.5V 3.33mV/V	Signal +	Blue	A
	Signal -	Green	B
	Excitation +	Red	C
	Excitation -	Yellow	D
	Calibration	Brown	E
	Calibration	Black	F
Output	Function	Color	6PIN
4-20mA	E+ / S+	Red	A
	E- / S-	Blue	B
	Calibration	Yellow	E
	Calibration	Black	F

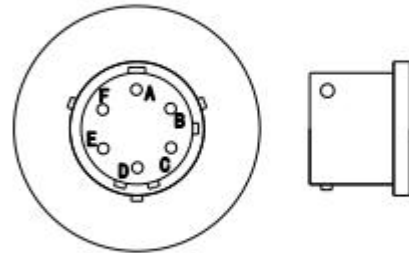

Output	Function	Color	8PIN
0-5V;1-5V; 0-10V; 0/0.5V 3.33mV/V	Excitation +	Red	A
	Signal +	Blue	B
	Excitation -	Yellow	C
	Signal -	Green /White	D
	Calibration	Brown	E
	Calibration	Black	F
	Blank	--	G, H
	Output	Function	Color
4-20mA	E+ / S+	Red	A
	E+ / S+	Blue	B
	Calibration	Yellow	E
	Calibration	Black	F

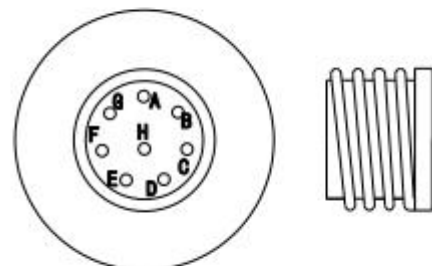



Melt Pressure Transducer Data Sheet

Ordering Guide

Model	Range (bar)	Output	Screw Thread	Electric connection	Accuracy	Diameter (mm)	Other requirement
CMPT124G-111T	*	*	*	*	*	*	---

Example:CMPT124G-111T-500Bar-2mV/V-M14*1.5-6PIN-J

